

Figure 1 Ø5 mold (type 01)

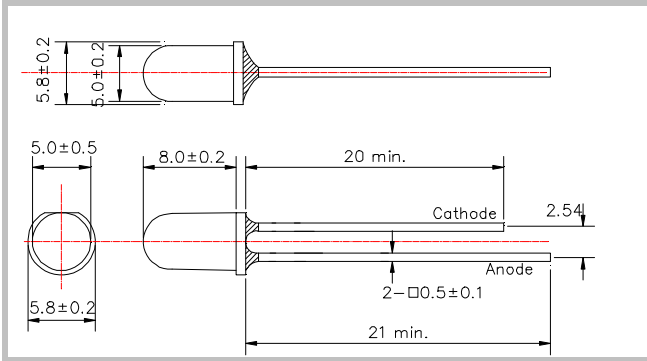

Figure 2 Ø5 mold (type 02)

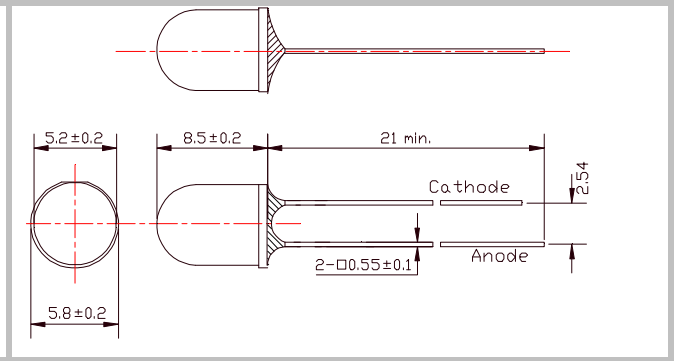

Figure 3 Ø5 mold (type 03)

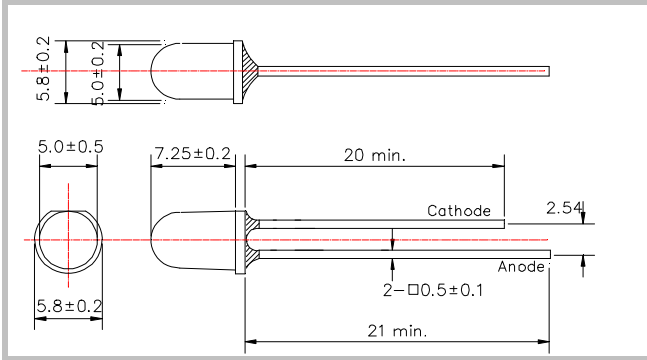

Figure 4 Ø5 mold (type 04)

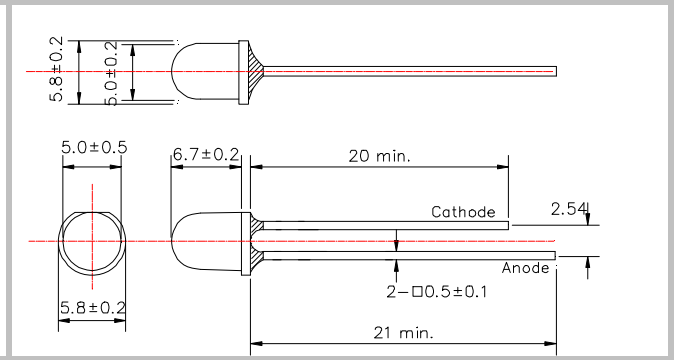

Figure 5 Ø5 mold (type 05)

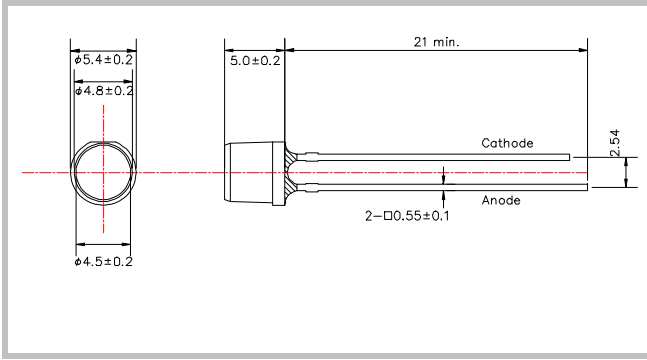

Figure 6 Ø5 mold (type 06)

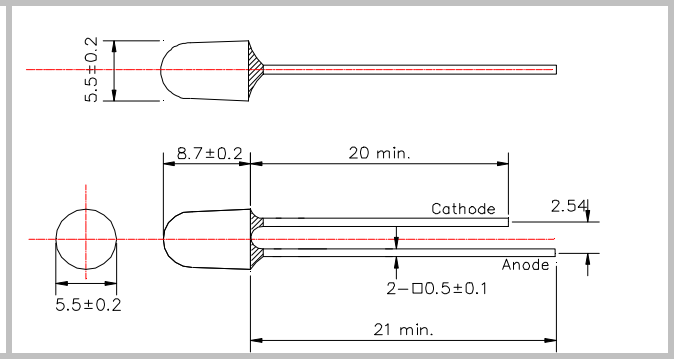

Figure 7 Ø5 mold (type 09)

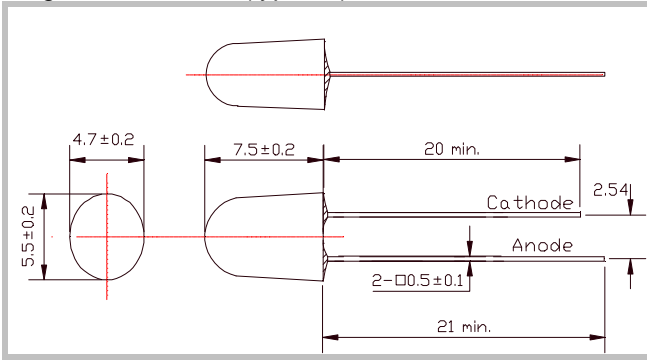

Figure 8 Ø10 mold (type 10)

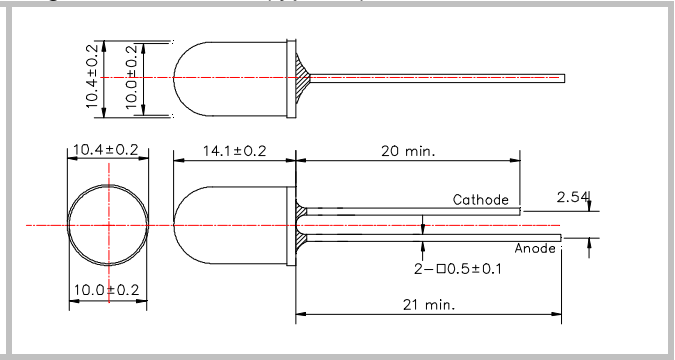

Figure 9 Ø3 mold (type 33)

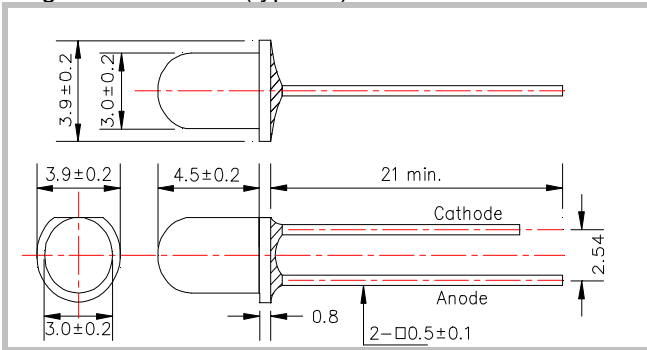

Figure 10 Ø3 mold (type 36)

